

ICC-ES Evaluation Report

ESR-3485

Reissued October 2023

This report also contains:

- LABC Supplement
- CBC Supplement
- FBC Supplement

Subject to renewal October 2025

ICC-ES Evaluation Reports are not to be construed as representing aesthetics or any other attributes not specifically addressed, nor are they to be construed as an endorsement of the subject of the report or a recommendation for its use. There is no warranty by ICC Evaluation Service, LLC, express or implied, as to any finding or other matter in this report, or as to any product covered by the report.

Copyright © 2023 ICC Evaluation Service, LLC. All rights reserved.

<p>DIVISION: 05 00 00 — METALS</p> <p>Section: 05 52 00 — Metal Railings</p>	<p>REPORT HOLDER: ULTRALOX™</p> <p>ADDITIONAL LISTEES: WILLIAMS ARCHITECTURAL PRODUCTS™</p> <p>HARMONY RAILING™</p>	<p>EVALUATION SUBJECT: ALUMINUM RAILING SYSTEM SERIES V800, C800, M600, I800, A800, O800, AND L800; MP400 MESH PANELS; ADA HANDRAILS; AND STANCHIONS</p>	
--	--	---	---

1.0 EVALUATION SCOPE

Compliance with the following codes:

- 2021, 2018, 2015, 2012, 2009, and 2006 [International Building Code® \(IBC\)](#)
- 2021, 2018, 2015, 2012, 2009, and 2006 [International Residential Code® \(IRC\)](#)

For evaluation for compliance with codes adopted by [Los Angeles Department of Building and Safety \(LADBS\)](#), see [ESR-3485 LABC and LARC Supplement](#).

For evaluation for compliance with codes adopted by the California Office of Statewide Health Planning and Development (OSHPD) and Division of State Architects (DSA), see [ESR-3485 CBC and CRC Supplement](#).

Property evaluated:

Structural

2.0 USES

The Aluminum Railing System Series V800, C800, M600, I800, A800, O800, and L800; MP400 Mesh Panels; ADA Handrails; and Stanchions described in this report are limited to exterior or interior use as a guardrail system for balconies, porches, and decks of residential and non-residential buildings constructed in accordance with the IBC and IRC.

3.0 DESCRIPTION

3.1 Railing Systems:

3.1.1 Aluminum Railing Systems:

The Aluminum Railing System Series V800, C800, M600, I800, A800, O800, and L800 are guards consisting of extruded aluminum posts and post sleeves, sub-rail panel with top and bottom channel rails and balusters, bottom-rail support leg, and top and bottom rail covers. The Aluminum Railing System components are produced from 6063-T5 aluminum alloy, the posts are produced from 6005A-T5 aluminum alloy, the post caps are produced from A380 aluminum alloy, and the post base plates are produced from A369 aluminum alloy. The Aluminum Railing System is available in seven different series: V800, C800, M600, I800, A800, O800, and L800; where each top rail is described by a designated series: Victorian (V), Colonial (C), Mission (M), Impressions (I), Aria (A), Optima (O) and Alta/Modern (L).

The minimum yield and tensile strengths, minimum thickness of the railing components, and manufacturing extrusion process are specified in the approved quality control documentation. The railing components are available in a white, black, bronze, or custom powder coated finish.

3.1.2 Aluminum Railing System with MP400 Mesh Panels:

The MP400 mesh panels are sub-rail panels for the Aluminum Railing System and consist of extruded prefabricated aluminum mesh panels factory tack welded to top and bottom channel rails. The sub-rail panels can be installed with the Aluminum Railing System consisting of extruded aluminum posts and top and bottom rail covers.

Each MP400 mesh panel is a prefabricated aluminum mesh produced from 6061-T6 aluminum alloy.

The minimum yield and tensile strengths, minimum thickness of the railing components, and manufacturing extrusion process are specified in the approved quality control documentation. The railing components are available in a white, black, or bronze powder coated finish.

3.1.3 ADA Handrails:

ADA Handrails consist of extruded aluminum round hollow pipe with cast-in-place aluminum wall returns and mid supports.

The ADA handrails consists of extruded 6063-T5 aluminum alloy and the 90° wall returns and mid supports are produced from A369 aluminum alloy.

The minimum yield and tensile strengths, minimum thickness of the railing components, and manufacturing extrusion process are specified in the approved quality control documentation. The railing components are available in a white, black, bronze, or custom powder coated finish.

3.1.4 Aluminum Railing System with Stanchions

The Aluminum Railing System can be supported to the substrate with stanchions into 2-inch (50.8 mm) square aluminum posts in lieu of post base plates and consists of guard components as described in Section 3.1.1. The stanchions are produced from extruded 6005A-T5 aluminum alloy.

The minimum yield and tensile strengths, minimum thickness of the railing components, and manufacturing extrusion process are specified in the approved quality control documentation. The railing components are available in a white, black, bronze, or custom powder coated finish.

3.2 Guard:

3.2.1 Aluminum Railing System:

The height of the railing assembly is 42 inches (1067 mm) above the walking surface. The top rail cover has a wall thickness of 0.055-inch (1.40 mm); and depending on the top rail series, the overall top rail width ranges from 2-inches (50.8 mm) minimum to 2 ½-inches (63.5 mm) maximum, and the overall top rail depth ranges from 1.83-inches (46.5 mm) minimum to 2.38-inches (60.5 mm) maximum. The bottom rail cover has a wall thickness of 0.055-inch (1.40 mm), a width of 1½-inches (38.1 mm), and a depth of 1½-inches (38.1 mm). For the sub-rail panels, both top and bottom h-channel rails having a varying wall thicknesses between 0.065-inch (1.65 mm) and 0.083-inch (2.11 mm) thick, a width of 1.38-inches (35.1 mm), and a depth of 0.97-inch (24.6 mm). Both top and bottom rail covers, and sub-rail panels are available in 6-foot (1.83 m) and 8-foot (2.44 m) lengths. They are produced from 6063-T5 aluminum alloy and come in a powder coated finish. The maximum railing span for each Aluminum Railing System series is noted in [Table 1](#).

The pickets are hollow rectangular extruded 6063-T5 aluminum. The pickets have a wall thickness of 0.050-inch (1.27 mm), a width of ½-inch (12.7 mm), and a depth of ¾-inch (19.1 mm) and come in a powder coated finish. Each picket is inserted in the pre-punched holes on the top and bottom h-channel rails of each sub-rail panel, with a center-to-center spacing of 4 ½-inches (114.3 mm).

The posts come in either 2-inches (50.8 mm) square hollow extruded 6005A-T5 aluminum with a wall thickness of 0.090-inch (2.28 mm) or 3-inches (76.2 mm) square hollow extruded 6005A-T5 aluminum with a wall thickness of 0.065-inch (1.65 mm); and both come in a powder coated finish. The optional post sleeve comes in 4-inches (101.6 mm) square hollow extruded 6063-T5 aluminum with a wall thickness of 0.080-inch (2.03 mm) and come in a powder coated finish. The post cap is produced from A380 aluminum alloy and is installed at the top of the extruded post and measures either 3-inches by 3-inches (76.2 mm by 76.2 mm) square or 4-inches by 4-inches (101.6 mm by 101.6mm) square. The post base plate is produced from A369

aluminum alloy and is installed at the bottom of the extruded post; it comes in either a 4.02-inches (102.1 mm) by 4.02 inches (102.1) square for the 2-inches (50.8 mm) square post or 4.99-inches (126.7 mm) by 4.99-inches (126.7 mm) square for the 3-inches (76.2 mm) square post. Each post base comes in a powder coated finish. The 6-foot (1.83 m) and 8-foot (2.44 m) railing systems utilize one intermediate bottom rail support leg located at the midspan. Each support leg is a 1½-inches (38.1 mm) square hollow extruded 6063-T5 aluminum with a wall thickness of 0.052-inch (1.32 mm) and comes in a powder coated finish.

The top and bottom rail connector clips are made from 0.080-inch (2.03 mm) thick 5052-H32 aluminum sheets and measures 1-inch (25.4 mm) wide by 0.94-inch (23.9 mm) long by 0.060-inch (1.52 mm) deep, with two 0.16-inch (4.06 mm) diameter holes for securing into the post.

See [Figure 1](#) for details of the components for the aluminum railing system.

The L-brackets are made from 0.080-inch (2.03 mm) thick 5052-H32 aluminum sheets and measures 1¼-inch (31.8mm) wide with 7⁄8-inch (22.2 mm) legs with two 0.196-inch (4.9 mm) diameter holes and one 0.330-inch (8.4 mm) diameter hole in each leg. The holes can secure the post to the bracket and bracket to supporting substrate. See [Figure 5](#) for component details.

The fascia bracket is made from 0.25-inch (6.4 mm) thick 5032-H32 aluminum sheets and measures 3.29-inches (83.5 mm) wide by 5.64-inches (143 mm) long by 6-inches (152.4 mm) in length. The sides have four 0.271-inch (6.9 mm) diameter holes for securing the post to the bracket. The lips have four 0.321-inch (8.2 mm) diameter holes for securing into the supporting substrate. See [Figure 6](#) for component details.

3.2.2 Aluminum Railing System with MP400 Mesh Panel:

The height of the railing assembly is 42 inches (1067 mm) above the walking surface. The top rail cover has a wall thickness of 0.055-inch (1.40 mm); and depending on the top rail series, the overall top rail width ranges from 2-inches (50.8 mm) minimum to 2½-inches (63.5 mm) maximum, and the overall top rail depth ranges from 1.83-inches (46.5 mm) minimum to 2.35-inches (59.7 mm) maximum. The bottom rail cover has a wall thickness of 0.055-inch (1.40 mm), a width of 1 ½-inches (38.1 mm), and a depth of 1 ½-inches (38.1 mm). Both top and bottom rail covers are available in 6-foot (1.83 m) and 8-foot (2.44 m) lengths. They are produced from 6063-T5 aluminum alloy and come in a powder coated finish.

The MP400 mesh panel consists of a prefabricated mesh panel produced from 0.181-inch (4.60 mm) diameter 6061-T6 aluminum wire; where the mesh panel is factory tack-welded to top and bottom channel rails produced from 6063-T5 aluminum having a wall thickness of 0.083-inch (2.11 mm) thick, a width of 0.589-inch (14.9 mm) and a depth of 0.625-inch (15.9 mm). The MP400 mesh panels come in nominal 36 inches (914.4 mm) wide by 48 inches (1219.2 mm) long pieces and come either in a brushed aluminum or a powder coated finish. The maximum railing span for each MP400 mesh panel is noted in [Table 1](#).

The posts come either in 2-inches (50.8 mm) square hollow extruded 6005A-T5 aluminum with a wall thickness of 0.090-inch (2.28 mm) or 3-inches (76.2 mm) square hollow extruded 6005A-T5 aluminum with a wall thickness of 0.065-inch (1.65 mm); and both come in a powder coated finish. The optional post sleeve comes in 4-inches (101.6 mm) square hollow extruded 6063-T5 aluminum with a wall thickness of 0.080-inch (2.03 mm) and come in a powder coated finish. The post cap is produced from A380 aluminum alloy and is installed at the top of the extruded post and measures either 3-inches by 3-inches (76.2 mm by 76.2 mm) square or 4-inches by 4-inches (101.6 mm by 101.6mm) square. The post base plate is produced from A369 aluminum alloy and is installed at the bottom of the extruded post; it comes in either a 4.02-inches (102.1 mm) by 4.02-inches (102.1) square for the 2-inches (50.8 mm) square post or 4.99-inches (126.7 mm) by 4.99-inches (126.7 mm) square for the 3-inches (76.2 mm) square post. Each post base comes in a powder coated finish.

The top and bottom rail connector clips are made from 0.080-inch (2.03 mm) thick 5052-H32 aluminum sheets and measures 1-inch (25.4 mm) wide by 0.94-inch (23.9 mm) long by 0.060-inch (1.52 mm) deep, with two 0.16-inch (4.06 mm) diameter holes for securing into the post.

See [Figure 2](#) for details of the components for the MP400 Mesh Panel.

3.3 ADA Handrails:

The ADA Handrails consist of 1½-inch (38.1 mm) outside diameter round hollow pipe and are produced from extruded 6063-T5 aluminum with a nominal wall thickness of 0.230-inch (5.8 mm). The handrail components, 90° wall returns and mid supports and spacers, are produced from A369 aluminum alloy. Each handrail component comes in a powder coated finish. See [Table 1](#) for maximum spans.

See [Figure 3](#) for details of the components for the ADA Handrails.

3.4 Aluminum Railing System with Stanchions

The Aluminum Railing System can be supported to the substrate with stanchions into 2-inch (50.8 mm) square aluminum posts in lieu of post base plates and consists of guard components as described in Section 3.2. The stanchions consist of extruded 1.715-inch wide by 1.715-inch long (43.6 mm by 43.6 mm) pieces and comes in 20-inch long (508 mm) lengths and are produced from 6005A-T5 aluminum alloy. See [Table 1](#) for maximum spans.

See [Figure 4](#) for details of guards with stanchions.

4.0 DESIGN AND INSTALLATION

4.1 Design:

The Aluminum Railing System Series V800, C800, M600, I800, A800, O800, and L800; MP400 Mesh Panels; and Stanchions are satisfactory to resist loads specified in Section 1607.9.1 for the 2021 IBC (Section 1607.8.1 for the 2018, 2015 and 2012 IBC; Section 1607.7.1 for the 2009 and 2006 IBC) and IRC Table R301.5, when installed at the maximum clear distance between the posts as noted in [Table 1](#). When the railing is supported on one or both ends by the supporting structure, the maximum clear distance between the post and the supporting structure or between the supporting structures must comply with the spans noted in [Table 1](#).

The ADA Handrails are satisfactory to resist loads specified in Section 1607.9.1 for the 2021 IBC (Section 1607.8.1 for the 2018, 2015 and 2012 IBC; Section 1607.7.1 for the 2009 and 2006 IBC) and IRC Table R301.5. The maximum clear distance between the supports is 72 inches (1828 mm); see [Table 1](#) for maximum spans.

4.2 Installation:

Installation must be in accordance with the manufacturer's published installation instructions, this report, and guard height and opening limitations provisions specified in Sections 1014 and 1015 of the 2021, 2018 and 2015 IBC (Sections 1012 and 1013 of the 2012, 2009 and 2006 IBC) and Sections R311 and R312 of the IRC, as applicable. The manufacturer's published installation instructions must be available at the jobsite at all times during installation.

Between the post: The sub-rail panel consisting of two h-channels and infill pickets is attached to an extrusion post on each end by installing top and bottom rail connector clips with #8 x $\frac{3}{4}$ -inch-long (19.05 mm) stainless steel TEK screws. Four screws (two inside and one on each side) per each top and bottom connector clip, as shown in [Figure 1](#). The bottom rail connector clip must be located $3\frac{3}{4}$ -inches (95.25 mm) from the top edge of the clip to the bottom of the post base at center. All connector clips must be installed with two #8 x $\frac{3}{4}$ -inch-long (19.05 mm) stainless steel TEK screws. Each top and bottom rail cover snaps over the sub-rail panel's corresponding top and bottom h-channel. Each support leg is fastened at the midspan of the bottom rail with one #8 x $\frac{3}{4}$ -inch-long (19.05 mm) stainless steel TEK screw.

Continuous top rail: A crossover bracket is secured to the top of each 2-inch (50.8 mm) post with two #8 x 1.5 inch-long (38.1 mm) stainless steel TEK screws. The sub-rail panel consisting of two h-channels and infill pickets is attached to the crossover bracket using two #8 x $\frac{3}{4}$ -inch-long (19.05 mm) TEK stainless steel screws. Bottom of sub-rail panel is attached with rail connector clips at the bottom as described in between post installations above. Each bottom rail cover snaps over the sub-rail h-channel. Each length of top rail snaps over post and top h-channel. See [Figure 1](#).

Each extruded post is attached to a post base plate with four M8 x 80 mm long stainless-steel lag screws, which are fastened on the underside of the post base plate, as shown in [Figure 1](#). The post base plate must be fastened to the supporting wood substrate with a minimum specific gravity of 0.50 using either four – $\frac{3}{8}$ -inch x 6-inch long (9.5 mm x 152.4 mm) GRK RSS wood screws or four – $\frac{5}{16}$ -inch x 6-inch long (7.9 mm x 152.4 mm) GRK RSS wood screws. When the supporting substrate is concrete having a minimum compressive strength of 3700 psi (25.5 MPa), each post base plate must be fastened to the supporting concrete substrate using four $\frac{1}{4}$ -inch x 3-inch long (6.35 mm by 76.2 mm) corrosion resistant coated concrete anchor bolts.

When the optional 4-inches (101.6 mm) square post sleeve is installed over an existing nominal 4-by-4 (101.6 mm x 101.6 mm) wood post, all wood post fastener connections to the supporting substrate and sub-rail connections through the post sleeve to the wood post must be designed by a registered design professional.

ADA Handrails must have each support attached to the supporting wood substrate with a minimum specific gravity of 0.49. Each 90° Wall Return and mid support is fastened to the wood substrate using three –

⁵/₁₆-inch x 4 inch-long (7.9 mm by 101.6 mm) construction lag screws. When each 90° Wall Return and mid support is fastened to 3-inches (76.2 mm) square hollow extruded 6005A-T5 aluminum with a wall thickness of 0.065-inch (1.65 mm), each connection must use three – #10 x 1½-inch long (38.1 mm) stainless steel TEK screws.

When stanchions are used to support 2-inch (50.8 mm) square aluminum posts in lieu of post base plates, the 2-inch (50.8 mm) square post must fit over each stanchion at a minimum length of 14.75 inches (374.6 mm). The connections of the stanchion to the stanchion mount and the mount to the supporting structure must be designed by a registered design professional.

When 2-inch (50.8 mm) square screen post at 96 inches long is installed with 42-inch Aluminum Railing System, the posts with L-brackets must be fastened to the supporting wood substrate with a minimum specific gravity of 0.39 where each connection must use either four - No.9 x 3¼-inch (82.5 mm) long SPAX screws or four - ¼ inch x 1¾-inch (6.4 mm x 44.5 mm) long TAPCON screws. See [Table 1](#) for spans and [Figure 5](#) for component details.

When fascia bracket assembly is used in lieu of post base for 3-inch (76.2 mm) square posts installed over the supporting concrete substrate having a minimum compressive strength of 3900 psi (26.9 MPa), the posts with fascia bracket assembly must be fastened to the supporting concrete substrate using four ¼-inch x 3-inch long (6.35 mm by 76.2 mm) corrosion resistant coated concrete anchor bolts. See [Table 1](#) for spans and [Figure 6](#) for component details.

5.0 CONDITIONS OF USE:

The Aluminum Railing System Series V800, C800, M600, I800, A800, O800, and L800; MP400 Mesh Panels; ADA handrails; and Stanchions described in this report comply with, or are a suitable alternative to what is specified in, those codes listed in Section 1.0 of this report, subject to the following conditions:

- 5.1 This product is limited to exterior or interior use as a guardrail system for balconies, porches, and decks of residential and non-residential buildings constructed in accordance with the IBC and IRC.
- 5.2 Installation must comply with this report, the manufacturer's published installation instructions and the applicable code. When the manufacturer's published installation instructions differ from this report, this report governs.
- 5.3 Only those fasteners and fastener configurations described in this report have been evaluated for the installation of the Aluminum Railing System Series V800, C800 M600, I800, A800, O800, and L800; MP400 Mesh Panels; and ADA handrails. The compatibility of the post base plate's fasteners with the supporting construction, including chemically treated wood, is outside the scope of this report.
- 5.4 The Aluminum Railing System Series V800, C800, M600, I800, A800, O800, and L800; MP400 Mesh Panels; and ADA Handrails must be directly fastened to supporting construction having adequate strength and stiffness. Where required by the code official, engineering calculations and construction documents consistent with this report must be submitted for approval. The calculations must verify that the supporting construction complies with the applicable building code requirements and is adequate to resist the loads imparted upon it from the products and systems discussed in this report. The documents must contain details of the attachment to the supporting structure consistent with the requirements of this report. The documents must be prepared by a registered design professional where required by the statutes of the jurisdiction in which the project is to be constructed.
- 5.5 The top rail of the Aluminum Railing System, for use as a handrail, is outside the scope of this report.
- 5.6 The connections of the stanchion to the stanchion mount and the stanchion mount to the supporting structure must be designed by a registered design professional and is outside the scope of this report.
- 5.7 The products are manufactured under a quality control program with inspections by ICC-ES.

6.0 EVIDENCE SUBMITTED

Data in accordance with the [ICC-ES Acceptance Criteria for Handrails and Guards \(AC273\)](#), dated June 2017 (editorially revised May 2021).

7.0 IDENTIFICATION

- 7.1 The Aluminum Railing System Series V800, C800, M600, I800, A800, O800, and L800; MP400 Mesh Panels; ADA handrails; and Stanchions described in this report are identified by a stamp, on each individual

piece or on the packaging, bearing the report holder's name (Ultralox), the product name (Aluminum Railing System Series V800, C800, M600, I800, A800, O800, and L800; MP400 Mesh Panels; ADA Handrails; and Stanchions), the allowable span, and the ICC-ES evaluation report number (ESR-3485).

Alternatively, the products described in this report are identified by a stamp, on each individual piece or on the packaging, bearing the additional listee's brand name (Williams Architectural Products, Harmony Railing), the product name (See [Table 2](#) of this report), the allowable span, and the ICC-ES evaluation report number (ESR-3485).

7.2 The report holder's contact information is the following:

ULTRALOX™
2955 LONE OAK DRIVE, SUITE 180
EAGAN, MINNESOTA 55121
www.ultralox.com

7.3 The Additional listees' contact information is the following:

WILLIAMS ARCHITECTURAL PRODUCTS™
2955 LONE OAK DRIVE, SUITE 180
EAGAN, MINNESOTA 55121
(855) 742-7245
www.williamsrail-fence.com

HARMONY RAILING™
2955 LONE OAK DRIVE, SUITE 180
EAGAN, MINNESOTA 55121
www.harmonyrailing.com

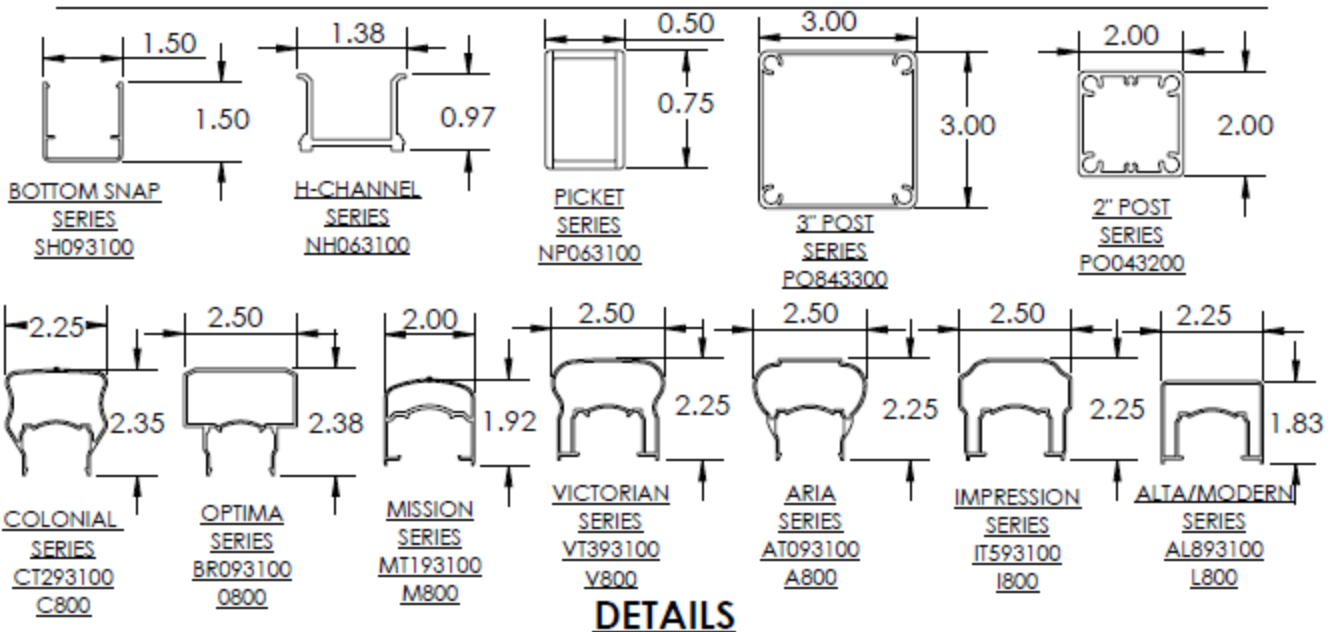
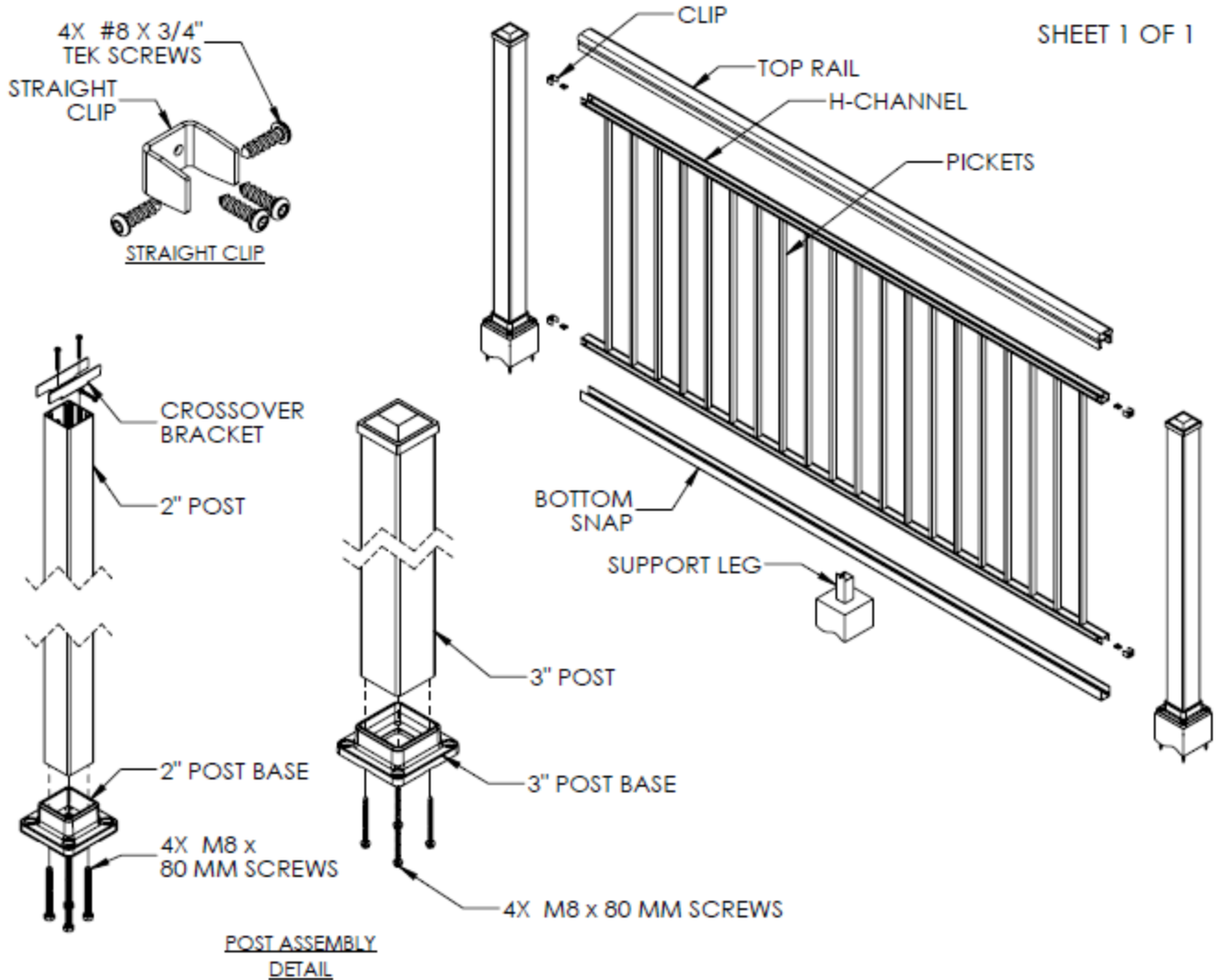

FIGURE 1—TYPICAL GUARDRAIL ASSEMBLY AND COMPONENT PROFILES

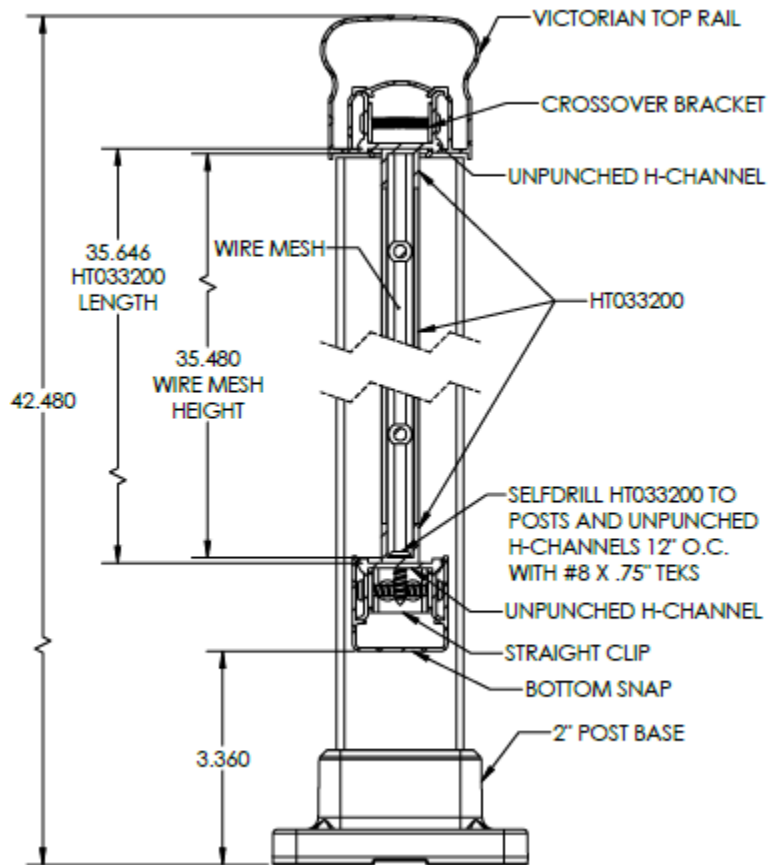
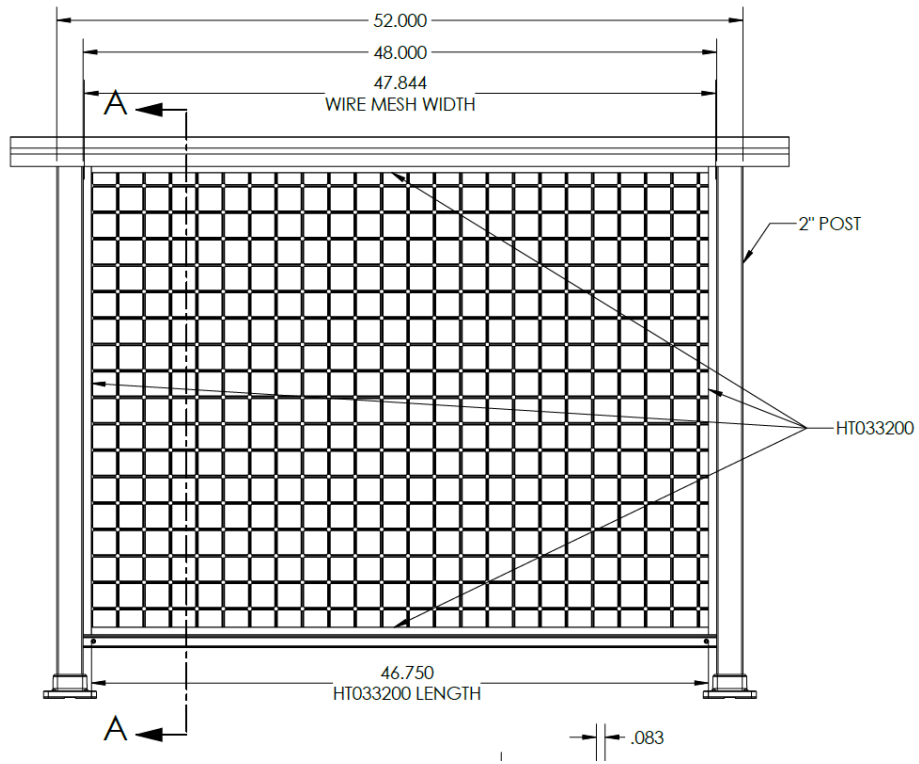

FIGURE 2—TYPICAL MP400 MESH PANEL ASSEMBLY AND COMPONENT PROFILES

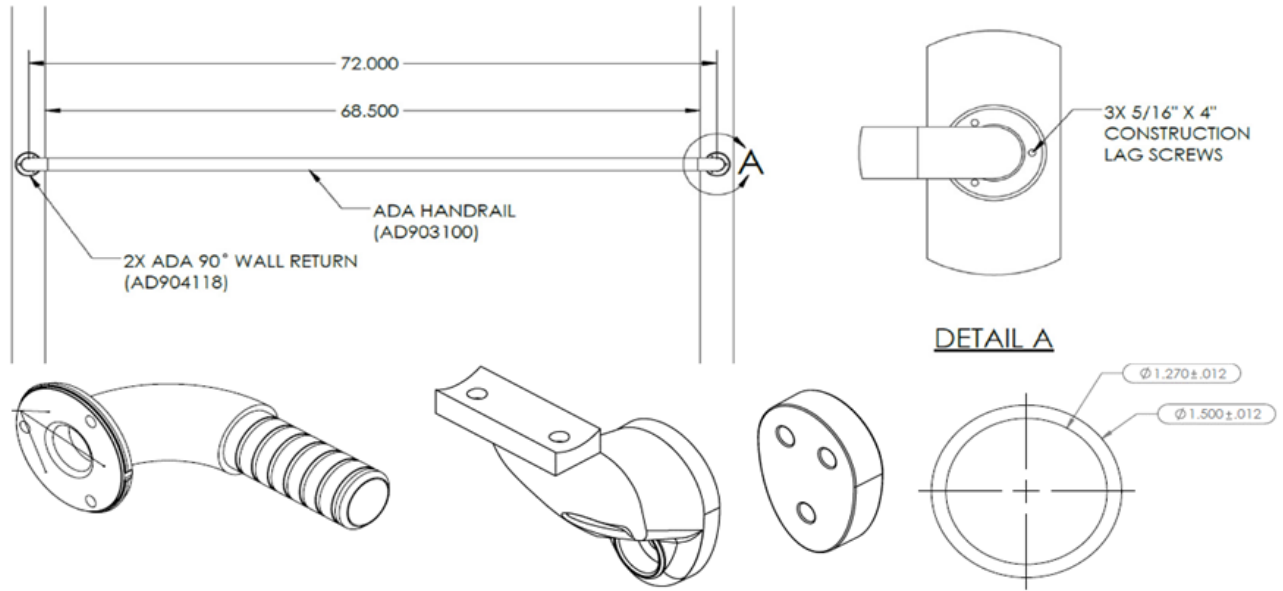

FIGURE 3—TYPICAL ADA HANDRAIL - COMPONENTS

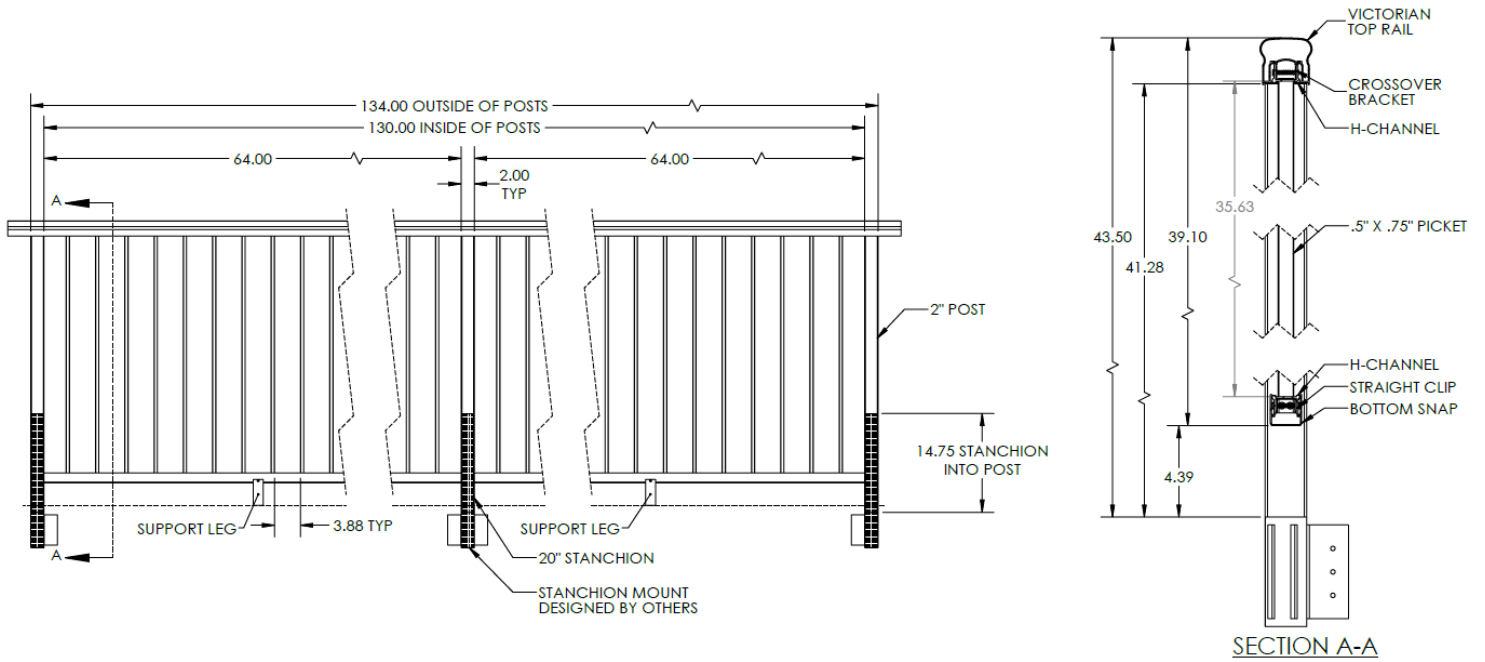

FIGURE 4—TYPICAL GUARD SYSTEM WITH STANCHIONS

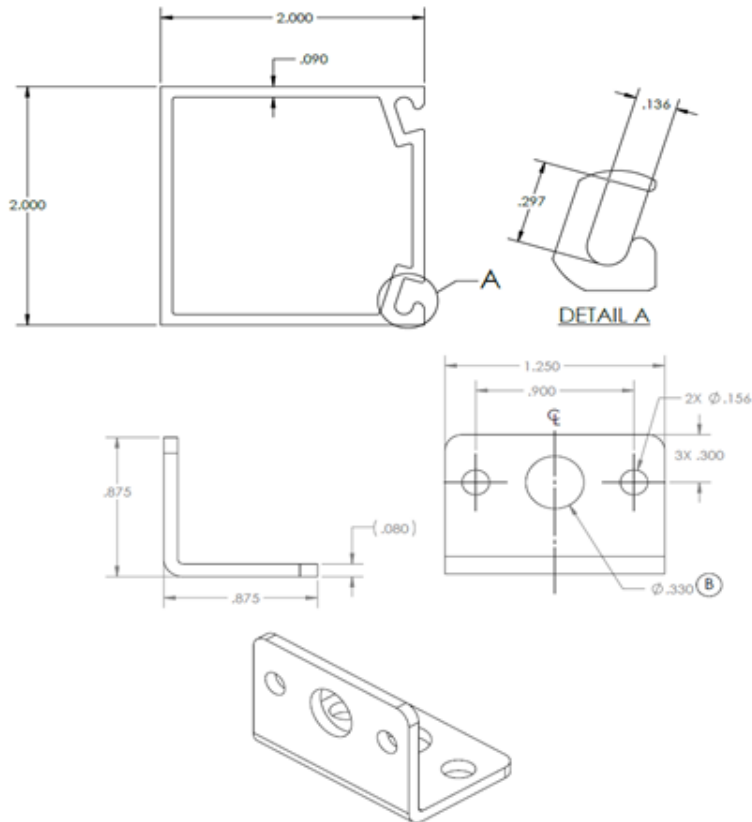

FIGURE 5—2-INCH SCREEN POST WITH L-BRACKETS ASSEMBLY

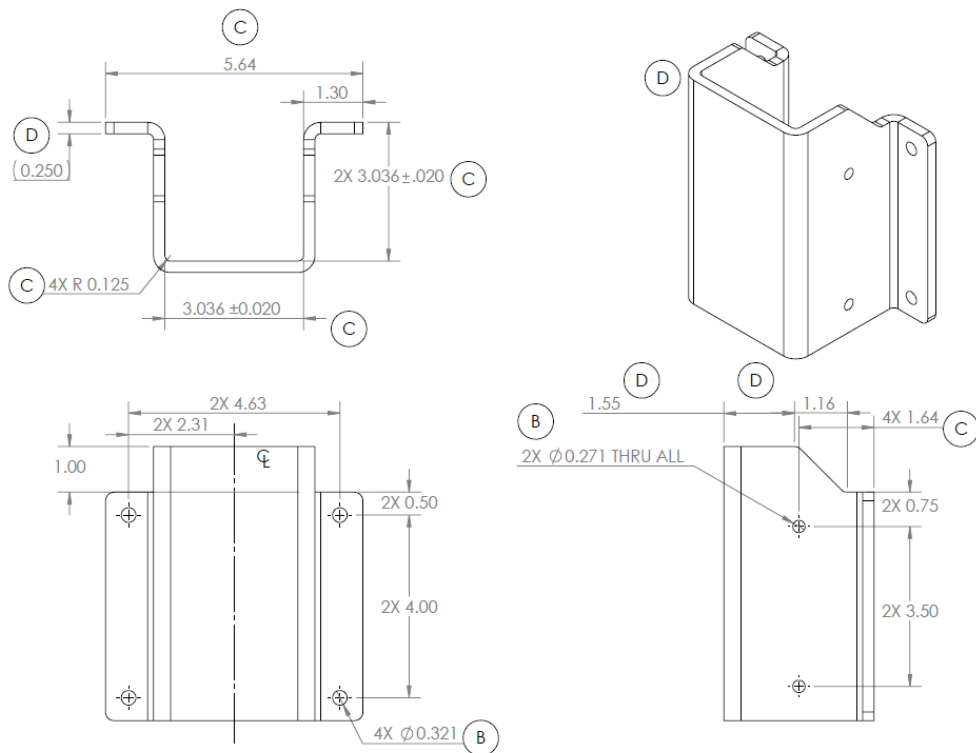

FIGURE 6—FASCIA BRACKET ASSEMBLY FOR 3" POST

TABLE 1—MAXIMUM GUARDRAIL SYSTEM SPANS¹

PRODUCT	POST HEIGHT (INCH)	MAXIMUM SPAN - IBC (INCH)	MAXIMUM SPAN - IRC (INCH)
ALUMINUM RAILING SYSTEM WITH 3-INCH ALUMINUM POSTS ATTACHED TO WOOD SUBSTRATE ²	42.000	68.300	91.313
ALUMINUM RAILING SYSTEM WITH 3-INCH ALUMINUM POSTS ATTACHED TO CONCRETE SUBSTRATE ³	42.000	69.430	91.313
ALUMINUM RAILING SYSTEM WITH 2-INCH ALUMINUM POSTS ATTACHED TO CONCRETE SUBSTRATE ³	42.000	66.000	91.313
ALUMINUM RAILING SYSTEM WITH 2-INCH ALUMINUM POSTS WITH STANCHIONS MOUNTED TO CONCRETE SUBSTRATE ⁴	42.000	66.000	91.313
ALUMINUM RAILING SYSTEM AT 42 INCH HEIGHT WITH 2-INCH SCREEN POST WITH L-BRACKETS ASSEMBLY ATTACHED TO WOOD SUBSTRATE ⁸	96.000	72.000	91.313
ALUMINUM RAILING SYSTEM WITH ALUMINUM 3" POSTS AND FASCIA BRACKET ASSEMBLY ATTACHED TO CONCRETE SUBSTRATE ⁹	42.000	55.960	91.313
ADA HANDRAILS WITH 90° BRACKET ASSEMBLY ATTACHED TO WOOD SUBSTRATE ⁵	N/A	72.000	72.000
ADA HANDRAILS WITH 90° BRACKET ASSEMBLY ATTACHED TO 3-INCH ALUMINUM POST WITH BACKER PLATE ⁶	N/A	72.000	72.000
ADA HANDRAILS WITH MIDSPAN BRACKET ASSEMBLY ATTACHED TO WOOD SUBSTRATE ⁵	N/A	72.000	72.000
ADA HANDRAILS WITH MIDSPAN BRACKET ASSEMBLY ATTACHED TO 2-INCH ALUMINUM POST ⁶	N/A	72.000	72.000
MP400 MESH PANEL ASSEMBLY WITH EITHER 2-INCH OR 3-INCH ALUMINUM POST ⁷	42.000	48.000	48.000

For SI: 1 inch = 25.4 mm

¹For Aluminum Railing System Series V800, C800, I800, A800, O800 and L800. For M600, the maximum span - IBC based on post and assembly is as noted in [Table 1](#), except the maximum span - IRC is 72 inches. Spans are from inside face to inside face of post.

²Wood substrate must have a minimum specific gravity of 0.50 where each connection must use either four - 3/8-inch x 6-inch long GRK RSS wood screws for IBC application or four - 5/16-inch x 6 inch-long GRK RSS wood screws for IRC application.

³Concrete substrate must have a minimum compressive strength of 3700 psi where each connection must use four - 1/4-inch x 3-inch long concrete anchor bolts supplied by Ultralox.

⁴Connections of stanchion-to-stanchion mount and stanchion mount to the substrate must be designed by a registered design professional.

⁵Wood substrate must have a minimum specific gravity of 0.49 where each connection must use three - 5/16-inch x 4-inch long construction lag screws.

⁶Each connection to aluminum post must use three - No. 10 x 1 1/2-inch long stainless steel TEK screws.

⁷Each connection to aluminum post must use four - No. 8 x 3/4-inch long stainless steel TEK screws.

⁸Wood substrate must have a minimum specific gravity of 0.39 where each connection must use either four - No.9 x 3 1/4-inch SPAX screws for IBC application or four - 1/4-inch x 1 3/4-inch long TAPCON screws for IRC application. See [Figure 5](#) for component details.

⁹Concrete substrate must have a minimum compressive strength of 3900 psi where each connection must use four - 1/4-inch x 3-inch long concrete anchor bolts supplied by Ultralox. See [Figure 6](#) for component details.

TABLE 2—COMPANY NAME AND PRODUCT NAME CORRELATION

COMPANY NAME	ULTRALOX™	WILLIAMS ARCHITECTURAL PRODUCTS™	HARMONY RAILING™
PRODUCT NAME	C800	C800	C800
	V800	-	V800
	M600	-	M600
	I800	-	I800
	A800	-	A800
	O800	-	-
	L800	-	L800
	MP400 Mesh Panel	-	MP400 Mesh Panel
	ADA Handrail	-	-

DIVISION: 05 00 00—METALS
Section: 05 52 00—Metal Railings

REPORT HOLDER:

ULTRALOX™

EVALUATION SUBJECT:

ALUMINUM RAILING SYSTEM SERIES V800, C800, M600, I800, A800, O800, AND L800; MP400 MESH PANELS; ADA HANDRAILS; AND STANCHIONS

1.0 REPORT PURPOSE AND SCOPE**Purpose:**

The purpose of this evaluation report supplement is to indicate that Aluminum Railing System Series V800, C800, M600, I800, A800, O800, and L800; MP400 Mesh Panels; ADA Handrails; and Stanchions, and ADA Handrails, described in ICC-ES evaluation report [ESR-3485](#), have also been evaluated for compliance with the codes noted below as adopted by the Los Angeles Department of Building and Safety (LADBS).

Applicable code editions:

- 2020 *City of Los Angeles Building Code* (LABC)
- 2020 *City of Los Angeles Residential Code* (LARC)

2.0 CONCLUSIONS

The Aluminum Railing System Series V800, C800, M600, I800, A800, O800, and L800; MP400 Mesh Panels; ADA Handrails; and Stanchions, described in Sections 2.0 through 7.0 of the evaluation report [ESR-3485](#), comply with the LABC Chapters 10 and 16 and LARC Chapter 3, and are subject to the conditions of use described in this supplement.

3.0 CONDITIONS OF USE

The Aluminum Railing System Series V800, C800, M600, I800, A800, O800, and L800; MP400 Mesh Panels; ADA Handrails; and Stanchions, described in this evaluation report supplement must comply with all of the following conditions:

- All applicable sections in the evaluation report [ESR-3485](#).
- The design, installation, conditions of use and identification of the Aluminum Railing System Series V800, C800, M600, I800, A800, O800, and L800; MP400 Mesh Panels; ADA Handrails; and Stanchions are in accordance with the 2018 *International Building Code*® (IBC) provisions noted in the evaluation report [ESR-3485](#).
- The design, installation and inspection are in accordance with additional requirements of LABC Chapters 10, 16 and 17, as applicable.
- Under the LARC, an engineered design in accordance with LARC Section R301.1.3 must be submitted.

This supplement expires concurrently with the evaluation report, reissued October 2023.

DIVISION: 05 00 00—METALS
Section: 05 52 00—Metal Railings

REPORT HOLDER:

ULTRALOX™

EVALUATION SUBJECT:

ALUMINUM RAILING SYSTEM SERIES V800, C800, M600, I800, A800, O800, AND L800; MP400 MESH PANELS; ADA HANDRAILS; AND STANCHIONS

1.0 REPORT PURPOSE AND SCOPE**Purpose:**

The purpose of this evaluation report supplement is to indicate that Aluminum Railing System Series V800, C800, M600, I800, A800, O800, and L800; MP400 Mesh Panels; ADA Handrails; and Stanchions, described in ICC-ES evaluation report ESR-3485, have also been evaluated for compliance with the codes noted below.

Applicable code editions:

- 2019 *California Building Code* (CBC)

For evaluation of applicable chapters adopted by the California Office of Statewide Health Planning and Development (OSHPD) and Division of State Architect (DSA), see Sections 2.1.1 and 2.1.2 below.

- 2019 *California Residential Code* (CRC)

2.0 CONCLUSIONS**2.1 CBC:**

The Aluminum Railing System Series V800, C800, M600, I800, A800, O800, and L800; MP400 Mesh Panels; ADA Handrails; and Stanchions, described in Sections 2.0 through 7.0 of the evaluation report ESR-3485, comply with CBC Chapters 10 and 16, provided the design and installation are in accordance with the 2018 *International Building Code*® (IBC) provisions noted in the evaluation report and the additional requirements of CBC Chapter 10, 16 and 17, as applicable.

2.1.1 OSHPD:

The Aluminum Railing System Series V800, C800, M600, I800, A800, O800, and L800; MP400 Mesh Panels; ADA Handrails; and Stanchions, described in Sections 2.0 through 7.0 of the evaluation report ESR-3485, comply with CBC Chapter 10 as amended [OSHPD 1, 1R, 2, 4 and 5], Chapter 16 and amendments [OSHPD 1R, 2, 3, and 5], and CBC Chapters 16A [OSHPD 1 and 4], provided the design and installation are in accordance with the 2018 *International Building Code*® (IBC) provisions noted in the evaluation report and the additional requirements of CBC Chapters 10, 16, 16A, and 17, as applicable.

2.1.2 DSA:

The Aluminum Railing System Series V800, C800, M600, I800, A800, O800, and L800; MP400 Mesh Panels; ADA Handrails; and Stanchions, described in Sections 2.0 through 7.0 of the evaluation report ESR-3485, comply with CBC Chapter 10 adopted section 1014 first paragraph [DSA AC], Chapter 10 [DSA SS and SS/CC], Chapter 11A as amended [DSA AC], Chapter 11B [DSA AC], Chapter 16 as amended [DSA-SS/CC], and CBC Chapter 16A [DSA/SS], provided the design and installation are in accordance with the 2018 *International Building Code*® (IBC) provisions noted in the evaluation report and the additional requirements of CBC Chapters 10, 11A, 11B, 16, 16A, and 17, as applicable.

2.2 CRC:

The Aluminum Railing System Series V800, C800, M600, I800, A800, O800, and L800; MP400 Mesh Panels; ADA Handrails; and Stanchions, described in Sections 2.0 through 7.0 of the evaluation report ESR-3485, comply with CRC Chapters 3, provided the design and installation are in accordance with the 2018 *International Residential Code*® (IRC) provisions noted in the evaluation report.

This supplement expires concurrently with the evaluation report, reissued October 2023.

DIVISION: 05 00 00—METALS
Section: 05 52 00—Metal Railings

REPORT HOLDER:

ULTRALOX™

EVALUATION SUBJECT:

ALUMINUM RAILING SYSTEM SERIES V800, C800, M600, I800, A800, O800, AND L800; MP400 MESH PANELS; ADA HANDRAILS; AND STANCHIONS

1.0 REPORT PURPOSE AND SCOPE**Purpose:**

The purpose of this evaluation report supplement is to indicate that Aluminum Railing System Series V800, C800, M600, I800, A800, O800, and L800; MP400 Mesh Panels; ADA Handrails; and Stanchions, described in ICC-ES evaluation report ESR-3485, have also been evaluated for compliance with the codes noted below.

Applicable code editions:

- 2020 *Florida Building Code—Building*
- 2020 *Florida Building Code—Residential*

2.0 CONCLUSIONS

The Aluminum Railing System Series V800, C800, M600, I800, A800, O800, and L800; MP400 Mesh Panels; ADA Handrails; and Stanchions, described in Sections 2.0 through 7.0 of the evaluation report ESR-3485, comply with the *Florida Building Code—Building and Florida Building Code—Residential*, provided the design and installation are in accordance with the 2018 *International Building Code*® and *International Residential Code*® provisions noted in the evaluation report.

Use of the Aluminum Railing System Series V800, C800, M600, I800, A800, O800, and L800; MP400 Mesh Panels; ADA Handrails; and Stanchions for compliance with the High-Velocity Hurricane Zone provisions of the *Florida Building Code—Building and Florida Building Code—Residential* has not been evaluated and is outside the scope of this evaluation report.

For products falling under Florida Rule 61G20-3, verification that the report holder's quality-assurance program is audited by a quality-assurance entity approved by the Florida Building Commission for the type of inspections being conducted is the responsibility of an approved validation entity (or the code official, when the report holder does not possess an approval by the Commission).

This supplement expires concurrently with the evaluation report, reissued October 2023.